

OMSTRAP

CS 801 YS

Automatic taping machine with fixed format manually adjustable for closing boxes with gummed paper:

The machine is suitable to be inserted in automatic lines.

The box is introduced into the machine by the operator.

Once inside the box is sealed with gummed paper at the top and bottom.

The advancement of the product takes place through lateral motorized belts.

The machine has been designed and built according to CE regulations.

Function management with Siemens PLC

Equipped with touch screen

Working table height 700-820 mm with wheels



MACHINE DIMENSIONS

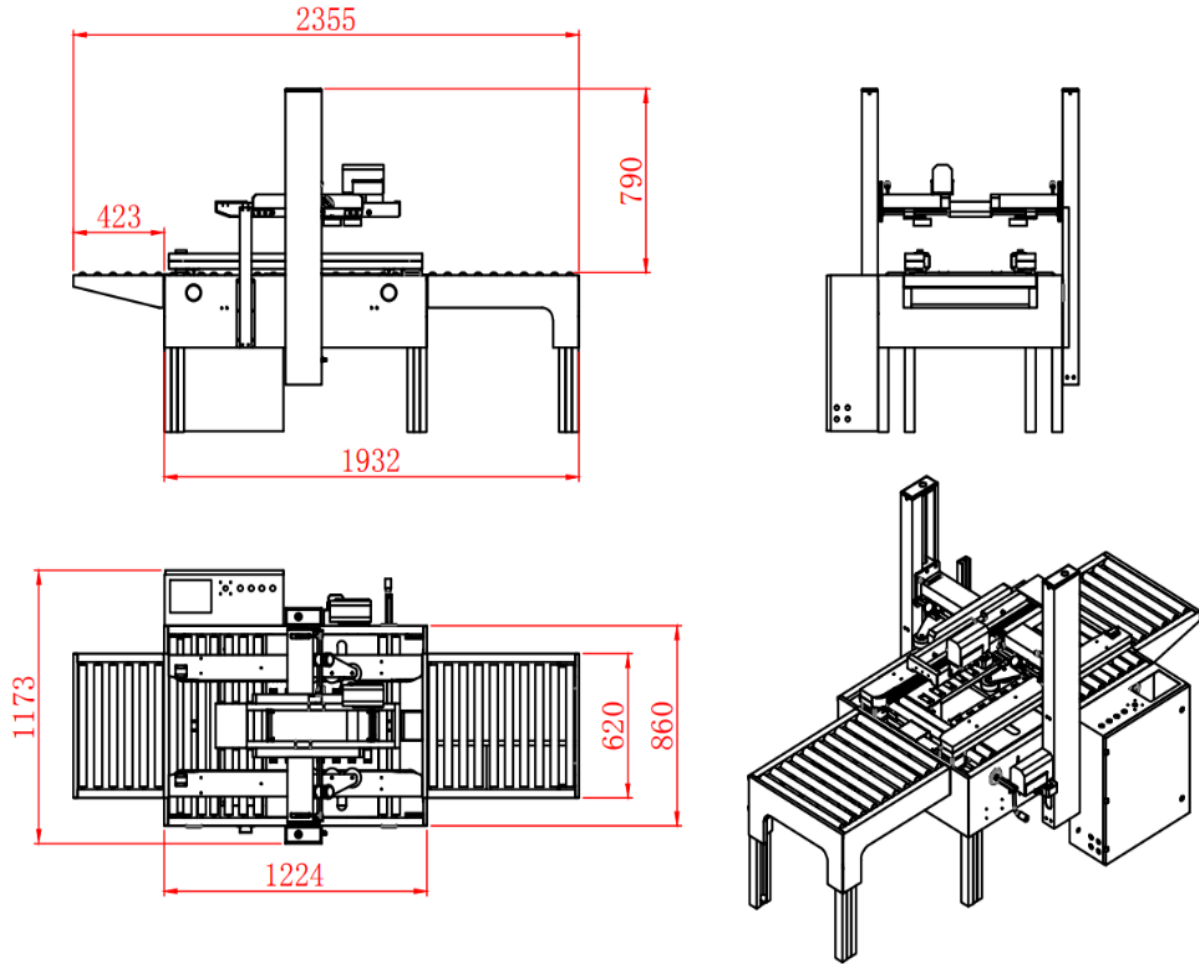

Box dimensions	Length: from 230 to infinity
	Width: from 130 to 550 mm
	Height: from 130 to 480 mm
Velocity	12 meters/minute
Roll width	72 mm gummed paper with filaments
Installed power	0.5 Kw
Voltage	220 Volt single-phase
Compressed air	5Kg/cm ²